

No. GT-NY05/10/15/25

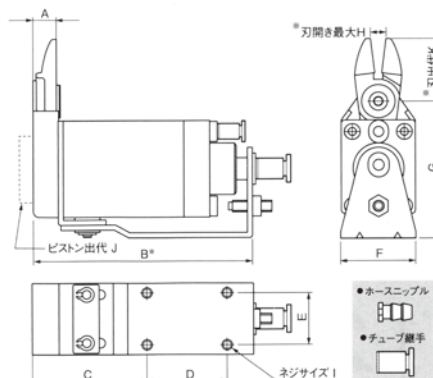

電腦編號	型 式	切斷能力 ϕ (mm)			
		軟質樹脂	硬質樹脂	銅 線	鐵 線
100203411	GT-NY05	3.0	2.0	1.6	1.0
	GT-NY05R	3.0	2.0	1.6	1.0
100203410	GT-NY05-4	3.0	2.0	1.6	1.0
	GT-NY05R-4	3.0	2.0	1.6	1.0
100203420	GT-NY10	3.5	2.3		
	GT-NY10R	3.5	2.3		
100203425	GT-NY15	4.0	2.6		
	GT-NY15R	4.0	2.6		
100203426	GT-NY25	5.0	3.4		
	GT-NY25R	5.0	3.4		
100203435	GT-NY25-6	5.0	3.4		
	GT-NY25R-6	5.0	3.4		

No. GT-NY03G/10G

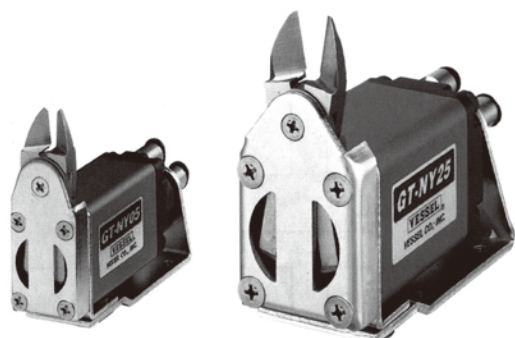
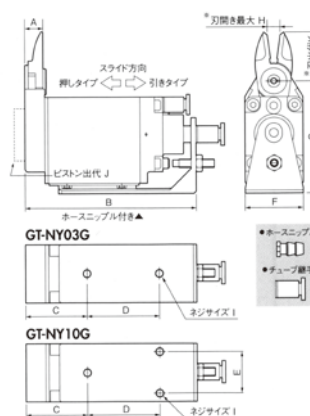
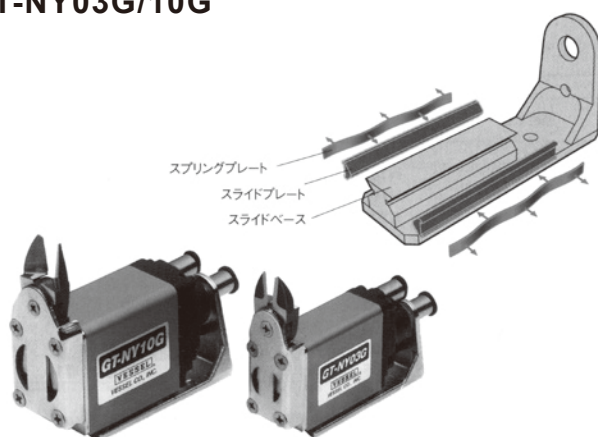

電腦編號	型 式	切斷能力 ϕ (mm)	
		軟質樹脂	硬質樹脂
	GT-NY03G	2.0	1.3
	GT-NY03GR	2.0	1.3
	GT-NY03G-4	2.0	1.3
	GT-NY03GR-4	2.0	1.3
	GT-NY10G	3.5	2.3
	GT-NY10GR	3.5	2.3
	GT-NY10G-4	3.5	2.3
	GT-NY10GR-4	3.5	2.3



No. GT-NY10S/25S

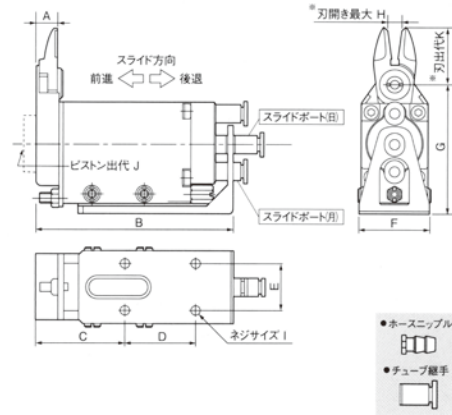
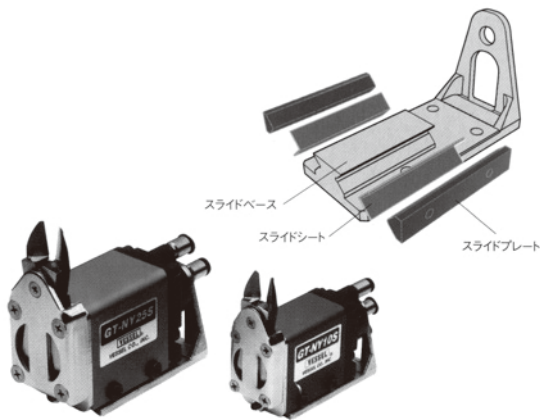

電腦編號	型式	切斷能力 ϕ (mm)	
		軟質樹脂	硬質樹脂
	GT-NY10S	3.5	2.3
	GT-NY25S	5.0	3.4

No. GT-NT03/05/10/20

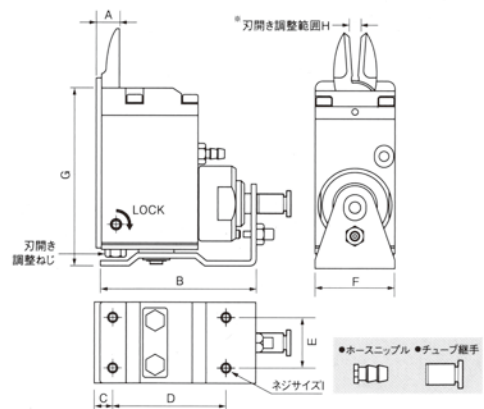
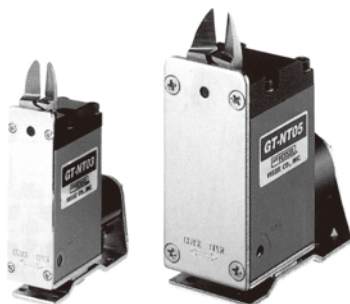

電腦編號	型式	切斷能力 ϕ (mm)	
		軟質樹脂	硬質樹脂
100205710	GT-NT03	1.5	1.0
100205720	GT-NT03R	1.5	1.0
	GT-NT03-4	1.5	1.0
	GT-NT03R-4	1.5	1.0
	GT-NT05	2.5	1.5
100205740	GT-NT05R	2.5	1.5
100205730	GT-NT05-4	2.5	1.5
	GT-NT05R-4	2.5	1.5
	GT-NT10	3.5	2.3
	GT-NT10R	3.5	2.3
100205750	GT-NT10-6	3.5	2.3
100205760	GT-NT10R-6	3.5	2.3
	GT-NT20	5.0	3.4
	GT-NT20R	5.0	3.4
100205770	GT-NT20-6	5.0	3.4
100205780	GT-NT20R-6	5.0	3.4