

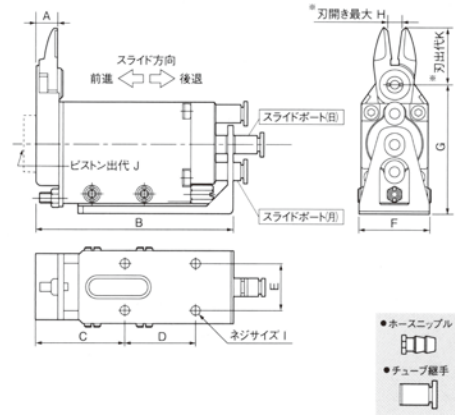

No. GT-NY10S/25S

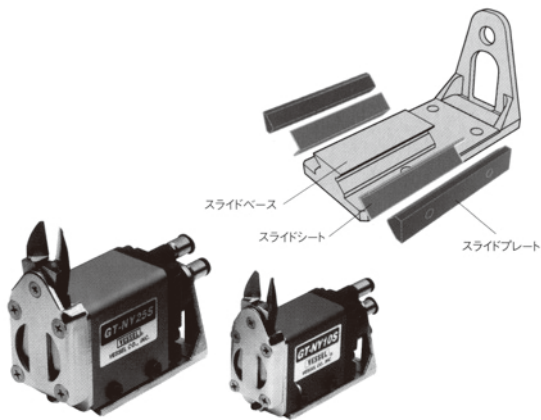

電機編號	型式	切断能力φ (mm)	
		軟質樹脂	硬質樹脂
	GT-NY10S	3.5	2.3
	GT-NY25S	5.0	3.4

No. GT-NT30/05/10/20

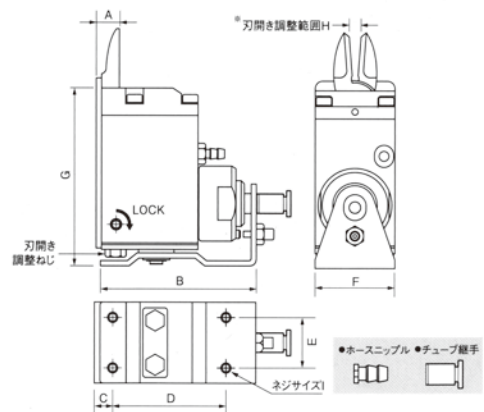
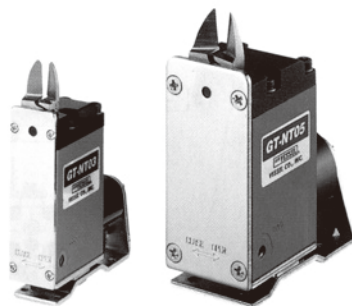

電機編號	型式	切断能力φ (mm)	
		軟質樹脂	硬質樹脂
100205710	GT-NT03	1.5	1.0
100205720	GT-NT03R	1.5	1.0
	GT-NT03-4	1.5	1.0
	GT-NT03R-4	1.5	1.0
	GT-NT05	2.5	1.5
100205740	GT-NT05R	2.5	1.5
100205730	GT-NT05-4	2.5	1.5
	GT-NT05R-4	2.5	1.5
	GT-NT10	3.5	2.3
	GT-NT10R	3.5	2.3
100205750	GT-NT10-6	3.5	2.3
100205760	GT-NT10R-6	3.5	2.3
	GT-NT20	5.0	3.4
	GT-NT20R	5.0	3.4
100205770	GT-NT20-6	5.0	3.4
100205780	GT-NT20R-6	5.0	3.4